

### General Description

It combines advanced trench MOSFET technology with a low resistance package to provide extremely low  $R_{DS(ON)}$ .

### Features

- Advance high cell density Trench technology
- Low  $R_{DS(ON)}$  to minimize conductive loss
- Low Gate Charge for fast switching
- Dual DIE in one package

### Application

- Power Management in Notebook Computer
- Portable Equipment and Battery Powered Systems

### Product Summary

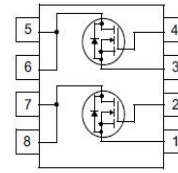

$V_{DS1} = 60V$   
 $V_{DS2} = 60V$   
 $R_{DS(ON)1} = 23m\Omega$   
 $R_{DS(ON)2} = 23m\Omega$   
 $I_{D1} = 23A$   
 $I_{D2} = 23A$

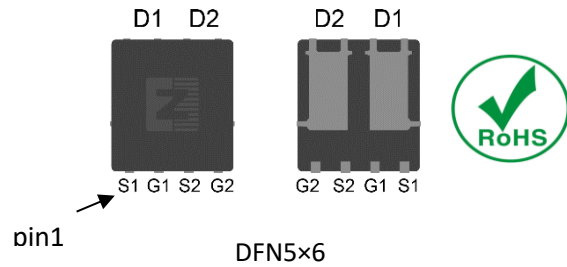

### Ordering Information:

Part NO.	ZMD68601N
Marking	ZMD68601
Packing Information	REEL TAPE
Basic ordering unit (pcs)	3000

### Absolute Maximum Ratings ( $T_C = 25^\circ C$ )

Parameter	Symbol	Rating	Unit
Drain-Source Voltage	$V_{DS}$	60	V
Gate-Source Voltage	$V_{GS}$	$\pm 20$	V
Continuous Drain Current	$I_{D@TC=25^\circ C}$	23	A
	$I_{D@TC=75^\circ C}$	17	A
	$I_{D@TC=100^\circ C}$	14	A
Pulsed Drain Current <sup>①</sup>	$I_{DM}$	46	A
Total Power Dissipation	$P_D@TC=25^\circ C$	20	W
Total Power Dissipation	$P_D@TA=25^\circ C$	1.7	W
Operating Junction Temperature	$T_J$	-55 to 150	$^\circ C$
Storage Temperature	$T_{STG}$	-55 to 150	$^\circ C$
Single Pulse Avalanche Energy	$E_{AS}$	90	mJ

**•Thermal resistance**

Parameter	Symbol	Min.	Typ.	Max.	Unit
Thermal resistance, junction - case	$R_{thJC}$	-	-	6	° C/W
Thermal resistance, junction - ambient	$R_{thJA}$	-	-	70	° C/W
Soldering temperature, wavesoldering for 10s	$T_{sold}$	-	-	265	° C

**•Electronic Characteristics**

Parameter	Symbol	Condition	Min.	Typ	Max.	Unit
Drain-Source Breakdown Voltage	$BV_{DSS}$	$V_{GS} = 0V, I_D = 250\mu A$	60			V
Gate Threshold Voltage	$V_{GS(TH)}$	$V_{GS} = V_{DS}, I_D = 250\mu A$	1.2	1.8	2.5	V
Drain-Source Leakage Current	$I_{DSS}$	$V_{DS} = 60V, V_{GS} = 0V$			1.0	$\mu A$
Gate- Source Leakage Current	$I_{GSS}$	$V_{GS} = \pm 20V, V_{DS} = 0V$			$\pm 100$	nA
Static Drain-source On Resistance	$R_{DS(ON)}$	$V_{GS} = 10V, I_D = 13A$		23	27	m $\Omega$
		$V_{GS} = 4.5V, I_D = 10A$		27	35	m $\Omega$
Forward Transconductance	$g_{FS}$	$V_{DS} = 25V, I_D = 8A$		10		S
Source-drain voltage	$V_{SD}$	$I_S = 13A$			1.28	V

**•Electronic Characteristics**

Parameter	Symbol	Condition	Min.	Typ	Max.	Unit
Input capacitance	$C_{iss}$	$V_{GS} = 0V, V_{DS} = 25V$ $f = 1MHz$	-	1850	-	pF
Output capacitance	$C_{oss}$		-	330	-	
Reverse transfer capacitance	$C_{rss}$		-	205	-	

**•Gate Charge characteristics( $T_a = 25^\circ C$ )**

Parameter	Symbol	Condition	Min.	Typ	Max.	Unit
Total gate charge	$Q_g$	$V_{DD} = 25V$	-	22	-	nC
Gate - Source charge	$Q_{gs}$	$I_D = 8A$	-	6	-	
Gate - Drain charge	$Q_{gd}$	$V_{GS} = 10V$	-	8	-	

Note: ① Pulse Test : Pulse width  $\leq 300\mu s$ , Duty cycle  $\leq 2\%$  ;

Fig.1 Power Dissipation

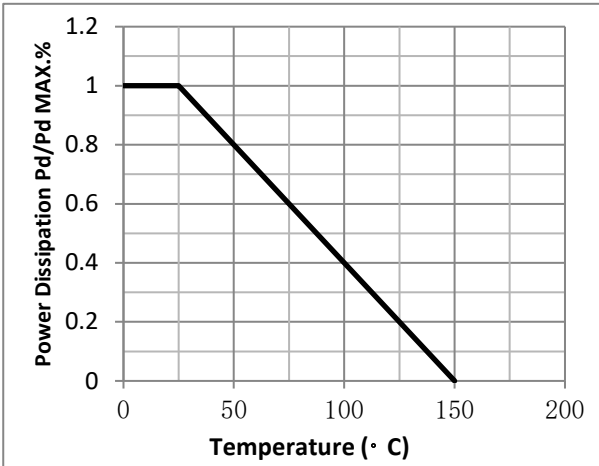

Fig.2 Typical output Characteristics

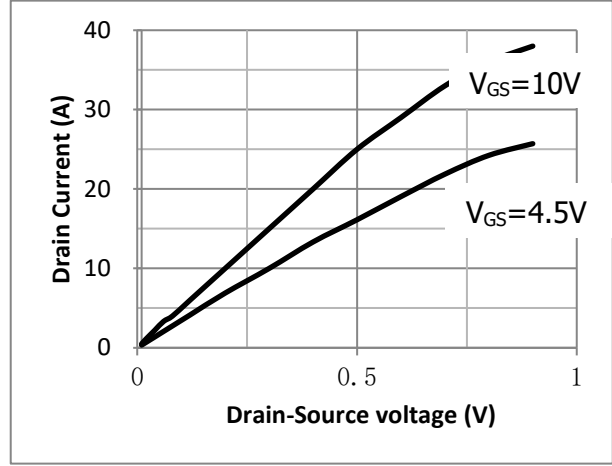

Fig.3 Threshold Voltage V.S Junction Temperature

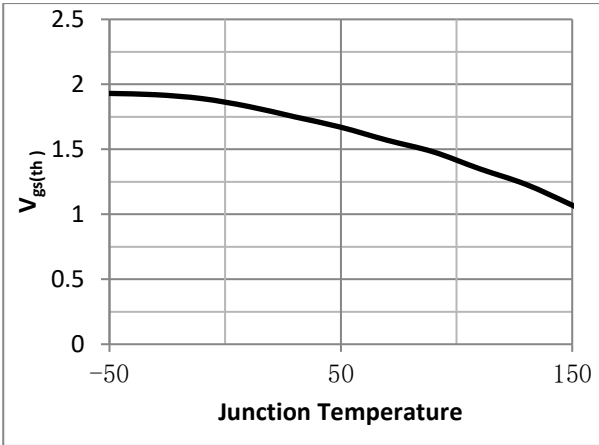

Fig.4 Resistance V.S Drain Current

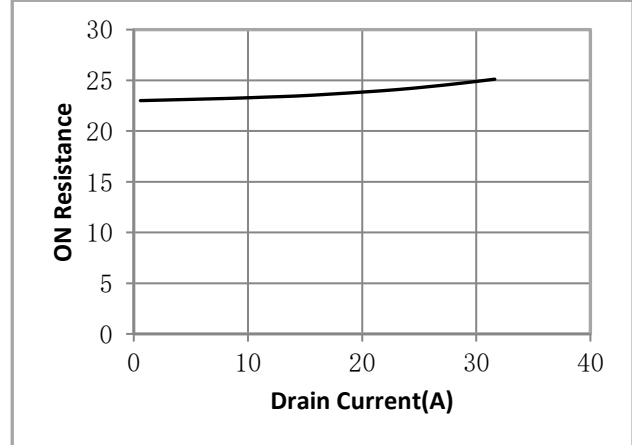

Fig.5 On-Resistance VS Gate Source Voltage

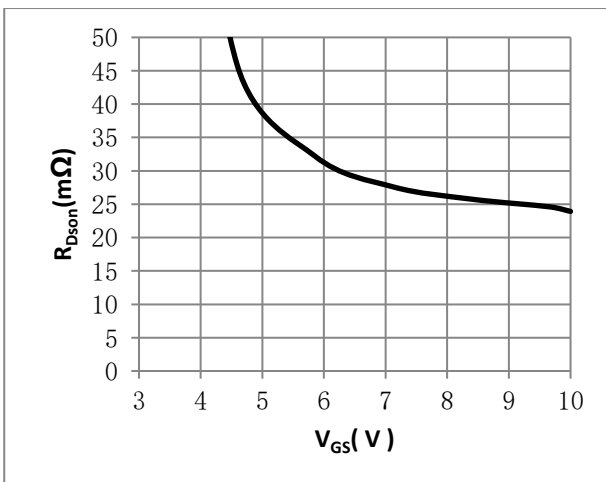

Fig.6 On-Resistance V.S Junction Temperature

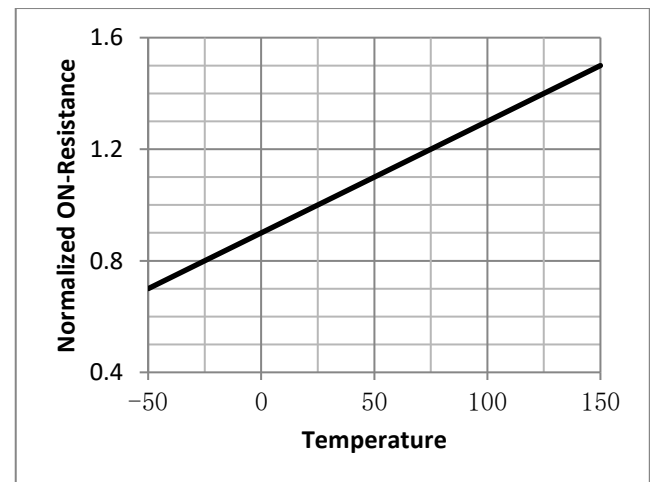

Fig.7 Gate Charge Measurement Circuit

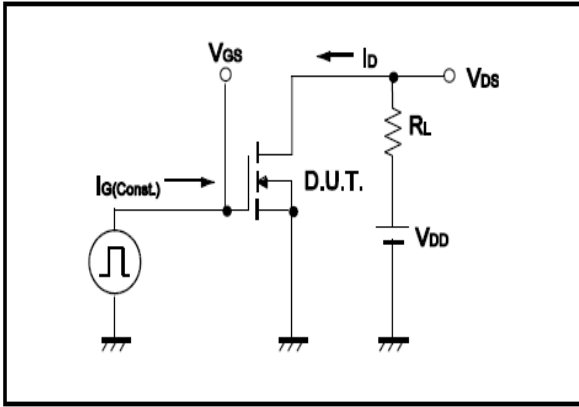

Fig.8 Gate Charge Waveform

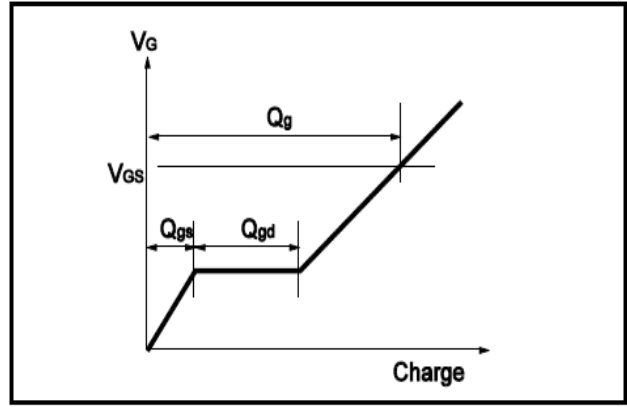

Fig.9 Switching Time Measurement Circuit

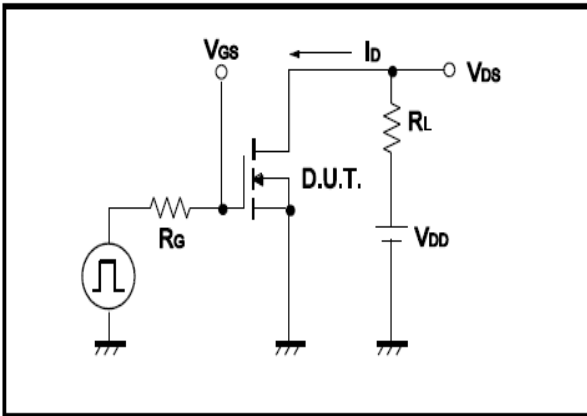

Fig.10 Switching Time Waveform

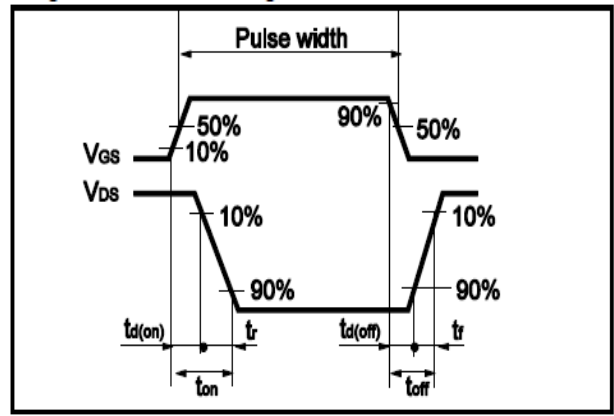

Fig.11 Avalanche Measurement Circuit

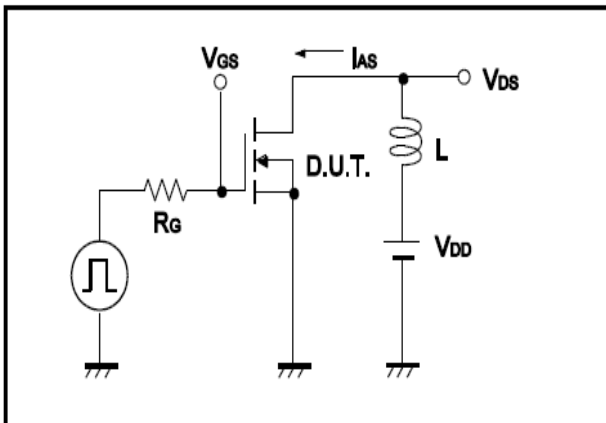
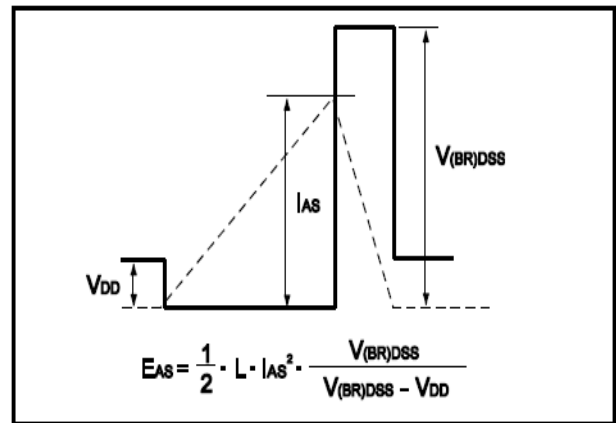

Fig.12 Avalanche Waveform





•Dimensions (DFN5x6)

Unit: mm

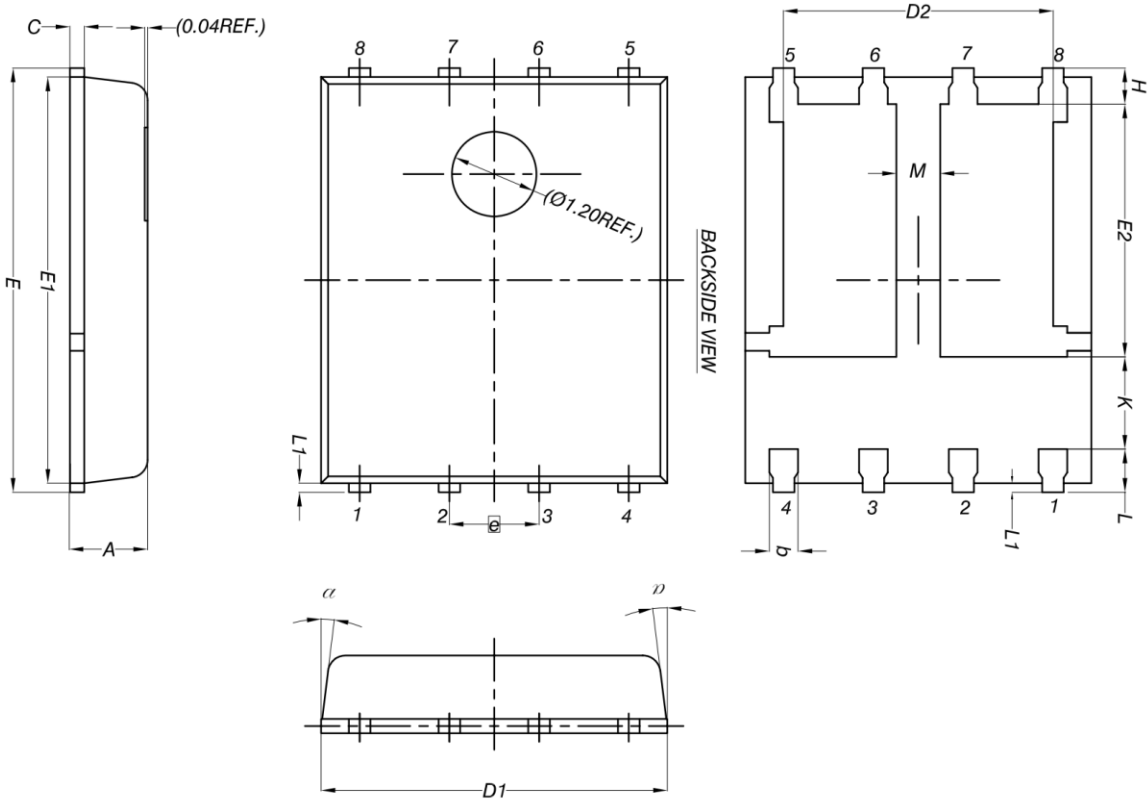

DIM.	MILLIMETERS		
	MIN.	NOM.	MAX.
A	0.90	1.00	1.10
b	0.33	0.41	0.51
C	0.20	0.25	0.30
D1	4.80	4.90	5.00
D2	3.61	3.81	3.96
E	5.90	6.00	6.10
E1	5.70	5.75	5.80
E2	3.38	3.58	3.78
e	1.27 BSC		
H	0.41	0.51	0.61
K	1.10	-	-
L	0.51	0.61	0.71
L1	0.06	0.13	0.20
M	0.50	-	-
α	0°	-	12°

